

Material: Carbon Spring Steel  
 Hardness: 42 to 50 HRC

Finish: Phosphating or as per requirements

**Type A**

Nominal size	s		d1	d2	h		for size
	Nominal size	tol	H14	js15	min.	max.	
3	0.5	+0.05	3.2	8	0.8	1.6	M3
3.5	0.5		3.7	8	0.9	1.8	M3.5
4	0.5		4.3	9	1	2	M4
5	0.5		5.3	11	1.1	2.2	M5
6	0.5		6.4	12	1.3	2.6	M6
7	0.8	+0.06	7.4	14	1.5	3	M7
8	0.8		8.4	15	1.5	3	M8
10	1	+0.07	10.5	21	2.1	4.2	M10
12	1.2		13	24	2.5	5	M12
14	1.6	+0.08	15	28	3	6	M14
16	1.6		17	30	3.2	6.4	M16
18	1.6		19	34	3.3	6.6	M18
20	1.6		21	36	3.7	7.4	M20
22	1.8	+0.1	23	40	3.9	7.8	M22
24	1.8		25	44	4.1	8.2	M24
27	2		28	50	4.7	9.4	M27
30	2.2		31	56	5	10	M30
33	2.2		34	60	5.3	10.6	M33

## Type B

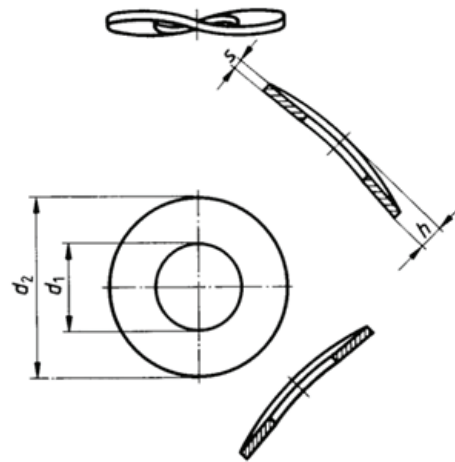

Nom. Size	s		d1 H14	d2js16	h		for Size
	Nom. Size	Tolerance			min.	max.	
3	0.5	+0.05	3.2	8	0.8	1.6	M3
3.5	0.5		3.7	8	0.9	1.8	M3.5
4	0.5		4.3	9	1	2	M4
5	0.5		5.3	11	1.1	2.2	M5
6	0.5		6.4	12	1.3	2.6	M6
7	0.8	+0.06	7.4	14	1.5	3	M7
8	0.8		8.4	15	1.5	3	M8
10	1	+0.07	10.5	21	2.1	4.2	M10
12	1.2		13	24	2.5	5	M12
14	1.6	+0.08	15	28	3	6	M14
16	1.6		17	30	3.2	6.4	M16
18	1.6		19	34	3.3	6.6	M18
20	1.6		21	36	3.7	7.4	M20
22	1.8	+0.01	23	40	3.9	7.8	M22
24	2		25	44	4.1	8.2	M24
27	2		28	50	4.7	9.4	M27
30	2.2		31	56	5	10	M30
33	2		34	60	5.3	10.6	M33
36	2.5		37	68	5.8	11.6	M36